

EcoTop Sport Handling, Fabrication and Processing

Fabrication

EcoTop Sport skate ramp panels can be sawed, routed, drilled and tapped with conventional wood-working or metalworking equipment. Carbide-tipped saw blades and router bits are recommended for cutting. They should be kept sharp to produce chip-free edges, the more teeth the better. High tool speed and low feed rates are advisable. The use of a hold-down bar is recommended to prevent vibration. Although unlikely, stress cracks can be avoided by ensuring that cutouts and holes are oversized.

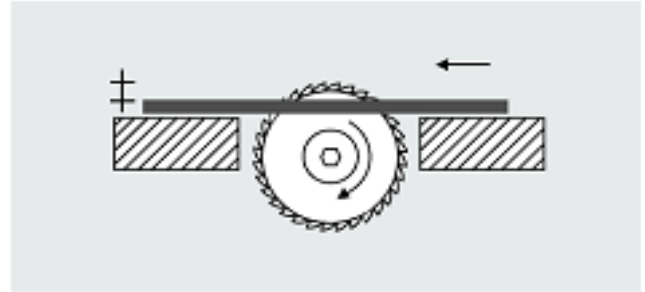

Routing

- Head speed- 18,000 rpm
- Feed rate- 200 in/min (based on very high quality carbide cutters)
- $\geq \frac{1}{2}$ " thick product use a finish pass after recommended depth passes to avoid hand sanding
- 1 blade depth pass per ($\frac{1}{4}$ " inch thickness $\frac{1}{2}$ "-2 passes; $\frac{3}{4}$ "-3 passes)
- Support under all cutting and drilling

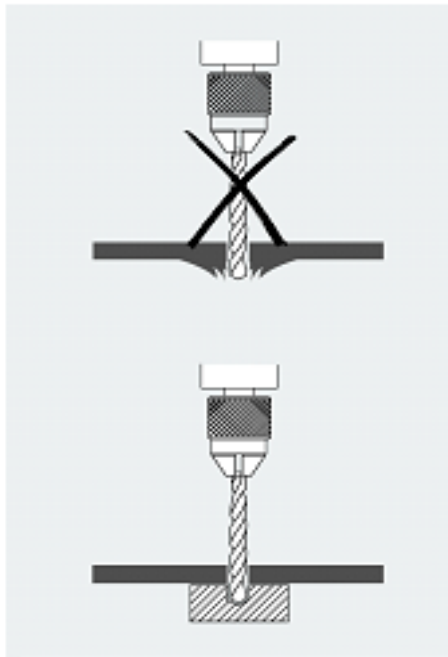

Drilling

Section	Number of revolutions	Start
5 mm	3,000	60-120 mm/min.
8 mm	2,000	40- 80 mm/min.
10 mm	1,500	30- 60 mm/min.

To reduce the likelihood of stress cracking with nails and screws, an oversized hole should be predrilled with a minimum distance to the edge of 1-1/2 times the hole of the diameter. Self-tapping screws can be used

in predrilled holes. Panels can be joined using metal brackets or clips.

Conditioning and Storage

The materials should be acclimated/conditioned a minimum of 48 hours before fabrication, like all products they have an ability to maneuver under extreme temperatures. Please also follow the other instructions below:

- The recommended conditioning/acclimation ambient storage temperature is approximately of 35°F-80°F with 45-55% relative humidity.
- Store in smooth, flat, non bending surfaces
- Do not store directly on concrete floors as moisture may migrate
- Do not Store in, under, or around heating units or air conditioning units.
- Keep Stored in plastic wrap until use